

WIRELESS MAGNETIC CALIPER

无线磁栅卡尺

WG09

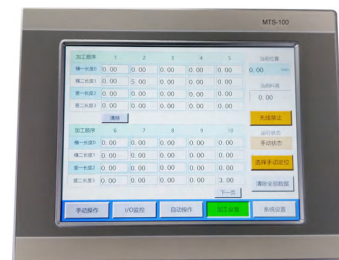

- 智能液晶带背光，大字符高清显示
Smart LCD with backlight, large character HD display
- 2节5号电池供电，嵌入式电池仓，更换电池便捷
2 section 5th battery power supply, built-in battery compartment, convenient battery replacement
- 近2米的超长卡量范围,分内卡和外公卡两种卡量模式
Nearly 2 meters of ultra-long card range, divided into internal card and external card two card mode
- 全铝合金外壳结构设计，磁栅非接触式测量
All aluminum alloy shell structure design, magnetic grid non-contact measurement
- 数显表采用两点自膨胀减振型便捷安装方式
The digital display meter adopts two-point self-expansion and vibration-damping type and convenient installation method.
- 可实现长距离(约100米)无线收发数据功能 (可选配)
Long-distance (about 100 meters) wireless data transmission and reception function (optional)
- 德国进口铝型材导轨及滑块，测量顺滑耐用
Germany imported aluminum profile rails and sliders, measuring smooth and durable

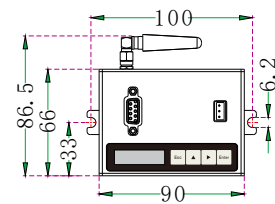
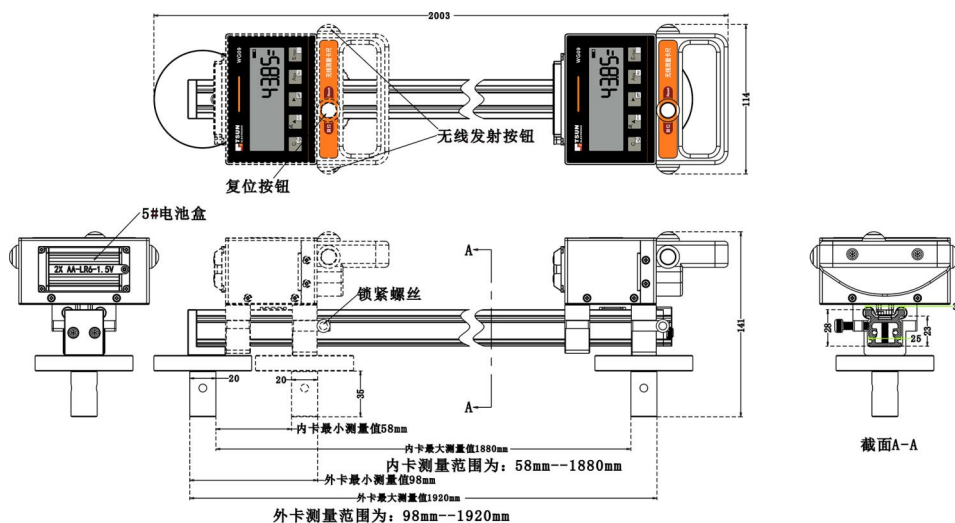

正视图
Front view

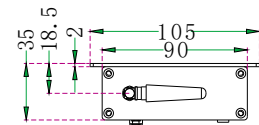

侧视图
Side view

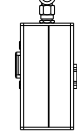

侧视图
Side view

特性 features	技术参数 Technical parameters	备注 Notes
重复精度 Repeatability accuracy	MAX. 0.01mm	
卡量速度 Card speed	Max.2m/s	
卡量范围 Card range	见尺寸图 See dimension chart	
电源 Power Supply	2节AA1.5V 2 AA1.5V	
消耗电流 Consumption current	Max.500uA	寿命约0.5年 Life expectancy is about 0.5 years
最大外观尺寸 Maximum Appearance Size	1877X117.8X114.5mm	
传感器防护等级 Sensor protection level	IP67	
工作温度 Operating temperature	-10 C.....+ 60 C	
储存温度 Storage temperature	-30 C.....+80 C	

(设置及使用要点，详见产品说明书)
(Setting and use points, please refer to the product manual for details.)